

FOUNTAIN HILLS SANITARY DISTRICT FACILITIES DESIGN STANDARDS

GENERAL

Unless otherwise noted herein, all facilities construction shall conform to the Uniform Standard Specifications for Public Works Construction, Maricopa Association of Governments, most recent addition (MAG Specs & MAG Details) and the Arizona Department of Environmental Quality Engineering Bulletin No. 11, whichever is most stringent.

WASTEWATER UNIT FLOW ESTIMATES

Per the latest version of the Fountain Hills Sanitary District Wastewater Master Plan, the following unit wastewater flow estimates and peaking factors shall be utilized in any submitted Basis of Design Report and/or for the sizing of sewer mains:

RESIDENTIAL FLOWS:	Unit Flow Per Capita:	77 gpcd
	Single Family Occupation:	2.5 persons per dwelling unit
	Multi Family Occupation:	1.98 persons per dwelling unit

Harmon Peaking Factor:	$PF = 1 + \frac{14}{4 + \left(\frac{\text{population}}{1000}\right)^{0.5}}$
------------------------	---

COMMERCIAL FLOWS:	Unit Flow Per Acre:	1,000 gpad
-------------------	---------------------	------------

Federov Peaking Factor:	$PF = \frac{2.69}{(0.06309 * Q)^{0.121}}$
-------------------------	---

Where Q = Avg. Daily Flow in gpm

SEWER LINES

1. Unless otherwise specified or required, all gravity sewer lines shall be constructed of SDR 35 PVC pipe conforming to ASTM D 3034. A certificate shall be furnished from the manufacturer attesting that the pipe meets the necessary ASTM requirements.
2. All mains and interceptors shall be constructed at a sufficient depth to serve the ultimate drainage area as determined by both the Sanitary District Master Plan and Town adopted general plan.
3. Sewer lines shall not be placed in less than a 20-foot-wide easement with at least a 10-foot-wide easement on the sewer side of the property line. The easement must be adequate to allow access by District personnel and equipment to perform all operation and maintenance of the facilities within.
4. All sewers shall be parallel to property lines or center lines or as close to parallel as possible. They shall not cross and re-cross the center line except in special cases approved by the District Manager.

5. The minimum horizontal distance from a sewer line to any parallel underground utility shall be 10 feet unless a lesser distance is approved by the District Manager. In no case shall the distance be less than 6 feet. A greater distance shall be used when required by the utility company.
6. Slopes of gravity sewer lines shall be sufficient to maintain a minimum velocity of 2.5 fps flowing full.
7. The maximum velocity in a gravity sewer line shall not exceed 10 fps unless otherwise approved by the District Manager.
8. The maximum velocity generated at the entrance to a drop manhole shall be no greater than 6 fps.
9. All gravity sewer mains shall be 8-inch diameter or larger.
10. All sewer lines shall have a minimum of 4 feet of cover, unless otherwise approved by the District Manager.
11. When a sewer line crosses a water pipe at a point at which the sewer line is less than 2 feet below the water pipe, the sewer line shall be encased in concrete for a distance of at least 6 feet in each direction from the crossing except in the case of a force main where the distance is 10 feet. When the sewer is a 4- or 6-inch house connection, no protection is required if the vertical separation is 12 inches or greater
12. When a sewer line crosses an irrigation ditch, there shall be at least 4 feet of cover between the flow line of the ditch and the crown of the sewer. If this condition cannot be met due to canals, washes, etc., there shall be a 6-inch-thick concrete encasement constructed in place over the sewer line. This shall extend not less than 2 feet on either side of the outside of the barrel of the sewer pipe and shall extend 5 feet beyond the limits of the canal, wash, etc.
13. Any gravity sewer line within a wash must be constructed with restrained joint DIP or PVC pipe encased in accordance with MAG Standard Detail No. 402. A scour depth analysis must be performed based upon the 100-year peak design discharge (Q100). If possible, the line must be buried a minimum depth of two feet below scour depth. The DIP and/or encasement shall extend a minimum of 10 feet outside the Q100 limits of the wash. The engineer shall submit the scour analysis with the final plans.
14. For sewer lines crossing a wash, pipelines may be required to be protected by installing cut-off(s) wall stabilize the scour depth. Cut-off wall(s) will be structurally designed to the scour conditions calculated.
15. When a sewer line is constructed such that it crosses under a retaining wall or other structure, the sewer line must be sleeved with a larger sized pipe approved by the District.
16. Where ductile iron pipe is allowed or required and is coupled to pipe of any other material type, rigid cast couplings shall be used.

17. All bolts used in fittings for underground installation shall be stainless steel. Deviations may be approved by the District Manager when conditions warrant the use of another material.
18. Pipe fittings utilized in the construction of any sewer line will be those approved for that specific type of service.
19. In all new sewer line construction, in-line wyes shall be used instead of saddles for connecting sewer services. Deviations may be approved by the District Manager in certain situations.
20. All sewer stubs shall end with a plug or cap and must have a green 1-rail marking post (fiberglass/plastic blend) installed from the end of the plug or cap up to 2 feet above grade.
21. Where ductile iron pipe is allowed or required, pipe shall be of the appropriate class and shall be installed with a liner or coating acceptable to the District Manager.
22. Where ductile iron pipe is allowed or required, the pipe shall be poly-wrapped.
23. All underground non-metallic sewer pipe shall be installed with insulated copper tracer wire or other approved conductor located adjacent to the piping. Access shall be provided to the tracer wire or the tracer wire shall terminate above ground at each end. The tracer wire size shall be not less than 18 AWG and the insulation type shall be suitable for direct burial.

MANHOLES

1. Manholes shall be installed as follows:
 - a. At all changes in grade,
 - b. At all changes in alignment,
 - c. At all lateral connections serving six or more housing units,
 - d. At all lateral connections from commercial buildings containing restaurants,
 - e. At lateral connections from some commercial buildings not containing restaurants (at District Manager's discretion), and
 - f. At all connections from private sewers (does not include connection from single family house lateral).
2. The maximum manhole spacing for all sewers is 400 feet.
3. Manholes on 8- and 10-inch diameter sewers that are less than 10 feet deep shall be 4-foot diameter with 24-inch frame and cover.
4. Manholes on 8- and 10-inch diameter sewers that are 10-feet deep or greater shall be 5-foot diameter with 30-inch frame and cover.
5. Manholes on 8- and 10-inch diameter sewers that are less than 10-feet deep but have more than one inlet shall be 5 foot diameter with 30 inch frame and cover.

6. On 12-inch diameter and larger sewer lines, manholes shall be 5-foot diameter with a 30-inch frame and cover.
7. Manholes at subdivision boundaries shall have stubs with shaped inverts in appropriate directions for future connections, if applicable. The contractor performing the future tie-in is responsible for verification and correction of defects in sewer stubs (including alignment).
8. Elevation drops across manholes shall be as follows:
 - a. .1 ft. drop for all angles less than 22-1/2 degrees,
 - b. .2 ft. drop for all angles 22-1/2 to 45 degrees, and
 - c. .3 ft. drop for all angles 45 to 90 degrees.
9. In some cases, the elevation drops across manholes as listed in No. 8 above may be exceeded with the approval of the District Manager. However, in no case will connecting sewers in a manhole have more than a 6-inch drop (flow line to flow line) without a drop connection.
10. All manhole bases shall be cast in place concrete. A Romac Style "LCT" manhole adapter gasket shall be used on all inlet and outlet pipes.
11. All manholes shall be constructed of precast concrete sections. Top sections shall be per MAG Standard Detail 420 with Type "A" top unless otherwise specified.
12. All manholes in washes shall be a minimum of 18-inches above finished grade but shall not exceed 2 feet. The actual wash topography and flow characteristics will dictate this height.
13. Manholes within the Q100 limits of washes must be designed to have structural protection against scour from 100-year storm flow. This protection may require encasing the entire manhole in concrete using sonotube or similar as a form or constructing a monolithic manhole.
14. Polypropylene manhole steps conforming to MAG Standard Detail 428 shall be provided in all manholes where pipe size is 12-inch diameter or less, unless otherwise specified.
15. The distance from finished grade to the first step in any manhole shall not exceed 32 inches.
16. The distance from the base to the bottom step in any manhole shall not exceed 16 inches.
17. Watertight manhole covers conforming to MAG Standard Detail 423 shall be provided for all manholes in washes or other unpaved areas.
18. Watertight manhole covers conforming to MAG Standard Detail 423 shall be provided for all manholes in a direct path of surface runoff or ponding.
19. Ram-nek shall be used between manhole sections and between the base and first section.

20. Grout used in manhole construction shall be non-shrink type, equivalent to the following: Gifford-Hill "Supreme", L&M "Crystex", Master Builders "Masterflow 713 Grout", or U.S. Grout "Five Star Grout".
21. A clean-out shall be installed on the end of a line if the line will not be extended. The spacing to the clean-out shall not be more than 100 feet. If the end of the line is more than 100 feet from the previous manhole, then a manhole must be installed instead of a clean-out.
22. All clean-outs shall be constructed in accordance with the LATERAL DEATILS.
23. Sewer taps in manholes shall be constructed with the tap invert 4-inches above the highest sewer invert at the manhole. See SERVICE TAP TO MANHOLE DETAIL.
24. When sewer lines of different sizes enter the same manhole, the smaller pipe shall not have its crown lower than the crown of the larger pipe. The crowns of the pipe must be on the same level or the crown of the smaller above the crown of the larger pipe.
25. Coat inside of all new manholes with insecticide paint using either Insecta or Super IQ. Application shall be in accordance with manufacturer's recommendations. A letter certifying that the application is in accordance with the manufacturer's recommendations along with a two-year warranty shall be provided to the District.
26. All manholes and cleanouts require a concrete collar at finished grade.

RAISING MANHOLES TO FINISHED GRADE

1. Any damaged grade rings will be replaced.
2. Grout work is required at all joints and will be free from cracks.
3. A sponge finish of Thoroseal or equivalent is required.
4. Where grade rings cannot be used, bricks are acceptable but must be mortared in and coated with a sponge finish of Thoroseal or equivalent. No voids will be allowed.
5. Any live manholes buried in the construction process must be uncovered and brought to grade within three calendar days.

PUMP STATION & FORCE MAIN MINIMUM REQUIREMENTS

1. Pump stations will not be considered unless a gravity option is not technically or legally feasible.
2. Pumping systems shall have at least one redundant pump.
3. Pumps shall be of the submersible design as manufactured by Flygt, Fairbanks-Morse, Hidrostal, or as approved by the District Manager.
4. Wet wells shall be six-foot diameter minimum.

5. A hatch cover system shall be utilized which allows each pump to be serviced through its own opening.
6. An odor control system shall be provided which is compatible with the most current being used by the District.
7. A fixed standby generator (propane fueled) shall be provided unless otherwise specified by the District Manager.
8. A telemetry system for remote monitoring of pump station conditions shall be provided which is compatible with the system currently in use by the District.
9. Standby generator and controls shall be installed in a concrete block building consistent in design with any architectural requirements of the District, homeowners association, or the appropriate local governmental entity. The surrounding area shall be landscaped complete with irrigation.
10. The entire facility shall be enclosed by an eight-foot tall block fence. A minimum 12-foot-wide rolling gate shall be provided for access into the facility.
11. A slop sink, water heater, and eyewash shall be provided in the building.
12. Unless otherwise specified by the District Manager, wet wells shall be sized such that at peak design flows, a minimum of one hour of storage shall be available.
13. The interior of the building shall be designed such that the controls are separated from the standby power source by a wall.
14. Above ground yard piping shall be ductile iron pipe with an interior coating acceptable to the District Manager unless otherwise specified.
15. A Sparling Tiger Mag shall be installed in accordance with manufacturer's recommendations.
16. The material for force mains 3-inches in diameter and larger shall be approved by the District Manager.
17. All force mains smaller than 3-inches in diameter shall be Schedule 80 PVC.
18. Any sewer force main within a wash must be constructed with restrained joint DIP or other material encased in accordance with MAG Standard Detail No. 402. A scour depth analysis must be performed based upon the 100-year peak design discharge (Q100). If possible, the line must be buried a minimum depth of two feet below scour depth. The DIP and/or encasement shall extend a minimum of 10 feet outside the Q100 limits of the wash. The engineer shall submit the scour analysis with the final plans.
19. For force mains crossing a wash, pipelines may be required to be protected by installing cut-off(s) wall stabilize the scour depth. Cut-off wall(s) will be structurally designed to the scour conditions calculated.

SEWER TAPS AND LATERALS (See SEWER LATERAL DETAIL “A”)

1. All sewer laterals shall be constructed to the lot line or interior edge of the PUE whichever is further onto property. A plug or a cap must be installed at the end of each lateral with a green 1-rail marking post (fiberglass/plastic blend) installed vertically from the plug or cap up to 2 feet above grade.
2. Single family homes shall be provided with a 4-inch diameter lateral.
3. Multiple family homes and apartments shall be provided with no less than a 6-inch diameter lateral.
4. Each commercial unit shall have its own lateral.
5. No taps shall be made on 15-inch diameter or larger sewers without the approval of the District Manager.
6. No tap shall have less than 4 feet of cover over its crown at the property line or easement line.
7. The flow line of a tap shall not be lower than 4 inches above the main outlet.
8. Proposed tap locations are to be shown on all plans but may be changed if necessary in the field if approved by the District Manager.
9. Laterals installed under retaining walls shall be sleeved with at least the next largest diameter pipe approved by the District.
10. The connection between a private ejector pump force main and a gravity sewer tap must be constructed using a glue type fitting.

GREASE TRAPS AND INTERCEPTORS

1. Any Food Service Establishment (FSE) that prepares food on site must have either a grease trap or a grease interceptor. Each FSE must have their own grease trap or interceptor and cannot have a shared one with another FSE.
2. If the FSE has more than four fixture units (FUs) in their kitchen, or if they have a dishwasher, an outside grease interceptor is required.
3. If the FSE has four or less FUs and/or does not have an interceptor, an outside grease interceptor may still be required if the menu items are deemed to be high in Fats, Oils and Grease (FOG) content, or at the discretion of the District Manager.
4. If the FSE is eligible for an under-sink grease trap, the minimum acceptable size for such a grease trap is 50 gpm/100lb capacity. The trap may be installed on top of the floor or below floor grade. The flow restriction valve shall be installed upstream of the grease trap and be constructed in such a fashion that it remains accessible for service, is properly vented, and remains in place at all times. If the flow restriction valve is not accessible for inspection and maintenance purposes, the installation will not be approved.

5. If the FSE is required to install an outside grease interceptor, the interceptor shall be sized in accordance with the drainage Fixture-Unit values as defined in the Plumbing Drainage Institute (PDI) Appendix A, Table A1.7.
6. The interceptor shall be:
 - a. A minimum of a 500-gallon capacity, two-chamber concrete container.
 - b. An interceptor with a capacity of 750 gallons or larger shall be a three-chamber concrete container.
 - c. No larger than 2500 gallons.
 - d. Installed with the interior inlet piping having a 90- degree elbow with a minimum of an 18 inch down spout.
 - e. Installed with the outlet side piping of the interceptor supplied with a sanitary-tee with a minimum of an 18-inch down spout.
 - f. Installed with the outlet side sanitary tee accessible from the last manhole for sampling purposes.
 - g. Installed with a “two-way” clean-out on both the inlet and outlet sides of the interceptor immediately before and after the interceptor.
 - h. Installed with vents on both the inlet and outlet piping to help reduce the buildup of gas and odor in and around the interceptor. Vent shall be run up to the roof of the establishment. The Town of Fountain Hills Building Safety Department should be consulted regarding any issues regarding the building code and how it pertains to venting.
 - i. Installed so that the outlet piping of the interceptor is plumbed directly to the sewer main as its own sewer service lateral, separate from all other shared or individual commercial and/or residential sewer service laterals.
 - j. Have the appropriate traffic rated or non-traffic rated cover.

BEDDING & BACKFILL

1. Bedding shall be select material and free from rock greater than 3/4 inch in size. A minimum of 4 inches of bedding material shall be used for all sewer construction except where special conditions dictate greater bedding depths. This same material shall be used to a depth of 12 inches above the top of the pipe. A minimum of 90% density is required except surrounding any structures, exposed utilities, under sidewalks, or within a road right of way where the minimum density is 95%.
2. Unless otherwise specified, screened native material may be used as backfill provided that no material is greater than 6 inches in size (at its largest dimension) and that no brush, trash or other deleterious material is used.

3. A minimum of four compaction tests are required manhole to manhole. Locations for testing will be determined by the District. If any test failures are experienced, the District reserves the right to require additional testing at no expense to the District.

PRIVATE SEWERS

1. The District will determine whether sewer infrastructure is to be public or private. All private sewers shall conform to District design standards and are subject to District inspection.
2. The District will not be responsible for the operation and maintenance of any private sewer infrastructure. The District's O & M responsibilities cease at the connection of the private sewer to the District's main line which must be made in a manhole (except single family service laterals).

MINIMUM DESIGN STANDARDS FOR RECLAIMED WATER DELIVERY LINES

1. Reclaimed water delivery lines shall be constructed of pipe material approved by the District Manager. The pipe material shall be purple or covered in purple poly-wrap.
2. Purple identification and locating tape shall be installed in the trench 1 foot above any reclaimed water delivery pipe. The tape shall be imprinted with the words "reclaimed water – non-potable".
3. All underground non-metallic reclaimed water pipe shall be installed with insulated copper tracer wire or other approved conductor located adjacent to the piping. Access shall be provided to the tracer wire or the tracer wire shall terminate above ground at each end. The tracer wire size shall be not less than 18 AWG and the insulation type shall be suitable for direct burial.
4. All reclaimed water delivery lines shall have a minimum cover of 5 feet.
5. Pumping systems shall include at least one redundant pump.
6. All pumping systems shall be metered using a Sparling Tiger Mag.
7. Gate valves shall be installed in the system at a distance no greater than 2,000 feet apart.
8. Any required air-release or air-vac valves shall be installed in a vault which allows access for maintenance. Any piping from the valves must be plumbed to drain into the nearest sanitary sewer manhole unless otherwise directed by the District Manager.
9. Valve boxes and meter boxes shall be purple in color.
10. Valve boxes and meter boxes located in washes or in unpaved surfaces shall be installed with a concrete collar.
11. Reclaimed water lines constructed in washes shall follow the same design standards as noted for sewer force mains.

CONSTRUCTION PLANS AND SPECIFICATIONS

1. **General**

- a. All plans shall be submitted on 24 x 36-inch sheets. The sheets shall be single profile.
- b. Vertical scale shall be 1" = 2' or 1" = 4'. Horizontal scale shall be 1" = 40' except for major streets and cases of unusual topography or complex situations, in which, the scale shall be 1" = 20'.
- c. All lettering and symbols shall be 1/8 inch, minimum, so as to be legible when plans are reduced to half size.
- d. As-Builts of original plan sheets shall be done on mylar and be sufficiently clear to produce clear prints and sepias. Electronic files of As-Builts shall also be submitted in pdf format.

2. **Subdivision Construction Drawings**

- a. Key map shall indicate:
 1. All streets, alleys, easements, lots, splits and parcels. Streets shall be identified by name and lots or parcels by number or letter, as the case may be.
 2. All sewer lines, clean-outs and manholes shall be shown.
 3. Index of sheets indicated by single line with arrows indicating beginning and end of sheet.
 4. Manholes shall be numbered consecutively, and the numbers indicated.
- b. Cover sheet shall contain:
 1. Vicinity and key map.
 2. Special details or pertinent specifications necessary for the construction of the sewer lines.
 3. Sewer lateral detail and service tap to manhole detail.
 4. Name of subdivision and developer
 5. Space for approval signatures with titles of each official (Fountain Hills Sanitary District, Town Engineer, and Maricopa County Environmental Services Department) and space for the date of signing.
 6. Estimated quantities.
- c. Each plan and profile sheet shall indicate:

1. Job title.
2. Sheet number.
3. North arrows to orient each line.
4. Existing utilities with size and location in right-of-way.
5. New construction with manholes, clean-outs, wyes, and sizes shown.
6. Match lines to indicate sheets that lines continue on.
7. Proposed finished grade shall be shown on profile with elevations and existing ground.

TESTING

1. The District shall be notified at least 24 hours in advance of any required testing.
2. All testing shall be performed by firms qualified to perform such tests.
3. All gravity sewer lines shall be air tested in accordance with ADEQ Engineering Bulletin 11 after all other adjacent utilities have been installed. Sewer and reclaimed water force mains shall be hydrostatically tested in accordance with ADEQ Engineering Bulletin 11.
4. All manholes shall be water tested in accordance with ADEQ Engineering Bulletin 11 or tested by negative air pressure in accordance with ASTM C 1244-93. Testing shall include all adjustment rings.
5. A minimum of four compaction tests are required manhole to manhole. Locations for testing will be determined by the District. If any test failures are experienced, the District reserves the right to require additional testing at no expense to the District.
6. All new gravity sewer lines shall be televised. Any defects in materials or workmanship observed shall be corrected. No standing water or reverse grades shall be allowed. The cost of final TV inspection shall be included in the project review and inspection fee. The contractor shall reimburse the District for all costs associated with any other TV inspections performed by the District.
7. Mandrel testing may be required at the discretion of the District Manager.
8. All grease, oil, or sand interceptors will be tested by filling the entire structure with water (to the rim elevation). There shall be a 24-hour period for structure to become saturated with water before an actual 24-hour test is monitored. No leakage shall be allowed. Tests will be witnessed by the District.
9. Prior to final inspection, all gravity sewer lines shall be cleaned by hydrovac.
10. A letter certifying the passing test results must be received by the District prior to acceptance.

TYPICAL SEWER NOTES

1. All construction shall conform to the Uniform Standard Specifications for Public Works Construction, Maricopa Association of Governments and the Uniform Standard Details for Public Works Construction, Maricopa Association of Governments most recent addition (MAG Specs & MAG Details); the Arizona Department of Environmental Quality Engineering Bulletin No. 11; and requirements of the Fountain Hills Sanitary District, whichever is most stringent.
2. Bedding material shall not be larger than 3/4 inch in size.
3. All facilities, materials, and workmanship are subject to the approval and acceptance of the Sanitary District Manager in order to assure the integrity of the Sanitary District's collection system.
4. Any work performed without the approval of the Sanitary District Manager and/or all work and materials not in conformance with the specifications is subject to removal and replacement at the contractor's expense.
5. Any deviation from the plans and specifications must be approved in writing by the engineer and Sanitary District Manager prior to acceptance.
6. The contractor must obtain all necessary permits and approvals from the Town of Fountain Hills, Maricopa County Environmental Services Department, and Maricopa County Air Quality Department prior to construction. The Sanitary District Manager shall be notified 24 hours prior to the different phases of construction for scheduling inspections.
7. The Contractor will uncover all existing lines being tied into to verify their location prior to trenching. The contractor will locate or have located all existing underground pipelines, telephone and electric conduits, and structures in advance of construction and will observe all possible precautions to avoid damage to the same.
8. Traffic control shall be maintained in accordance with MAG Specification 401, Manual of Traffic Control Devices for Streets and Highways (latest edition) and the City of Phoenix Traffic Barricade Manual.
9. Backfilling shall not be started until all lines are approved by the Sanitary District Manager.
10. A minimum of four compaction tests are required manhole to manhole. Locations for testing will be determined by the District. The contractor will notify the testing lab, coordinate with the inspector and testing lab, and pay the costs to perform the tests. Copies of the test results shall be sent to both the Sanitary District Manager and Town Engineer. If any test failures are experienced, the District reserves the right to require additional testing at no expense to the District.
11. When a sewer crosses a water pipe at a point at which the sewer is less than 2 feet below the water pipe, the sewer shall be encased in concrete for a distance of at least 6 feet in each direction from the crossing, except in the case of a force main where the distance is 10 feet. When the sewer is a 4- or 6-inch house connection, no protection is required if the vertical separation is 12 inches or greater.

12. All sewer laterals shall be constructed to the lot line or interior edge of the PUE whichever is further onto property. A plug or cap must be installed at the end of each lateral with a green 1-rail marking post (fiberglass/plastic blend) installed vertically from the plug or cap up to 2 feet above grade.
13. All sewer stubs shall end with a plug or cap and must have a green 1-rail marking post (fiberglass/plastic blend) installed from the end of the plug or cap up to 2 feet above grade.
14. All sewer lines will be air tested in accordance with ADEQ Engineering Bulletin No. 11. All manholes will be water tested in accordance with ADEQ Engineering Bulletin No. 11 or tested with negative air pressure in accordance with ASTM C 1244-93. A letter certifying the passing test results must be received by the District prior to acceptance.
15. Any previously tested sewer lines broken during the installation of other adjacent utilities will be repaired and retested to the satisfaction of the Sanitary District Manager.
16. Acceptance of the completed improvements will not be given until full size photo mylar reproducible "As Builts", along with electronic files in pdf format of all As-Built sheets, have been submitted to and approved by the Sanitary District Manager.
17. Non-shrink grout shall be used in the construction of all manholes.
18. All sanitary sewer pipe shall be polyvinyl chloride (PVC), unless otherwise noted, in accordance with MAG Specifications. A certificate shall be furnished from the manufacturer attesting that the pipe meets the required ASTM requirements, PVC pipe SDR 35, ASTM D 3034.
19. All cleanouts shall be constructed in accordance with the District's standard design.
20. Compliance with all town, county, state and Federal rules and regulations pertaining to job safety shall be the responsibility of the contractor.
21. The inside of all new manholes shall be coated with insecticide paint in accordance with District requirements. Use either Insecta or Super IQ. Application shall be in accordance with manufacturer's recommendations. A letter certifying that the application is in accordance with the manufacturer's recommendations along with a two-year warranty shall be provided to the District.

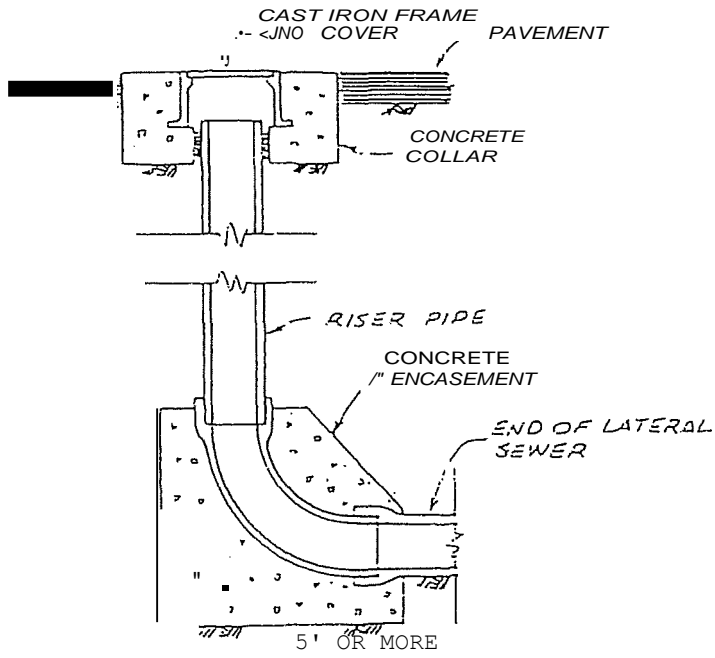

Vertical lateral cleanout

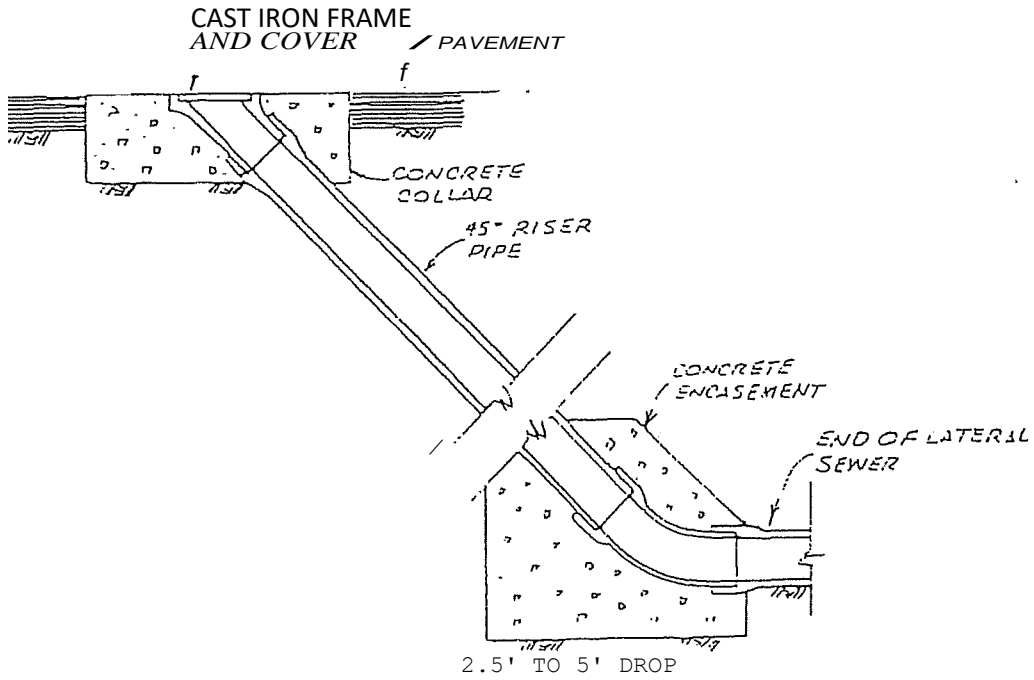

SLANT LATERAL CLEANOUT

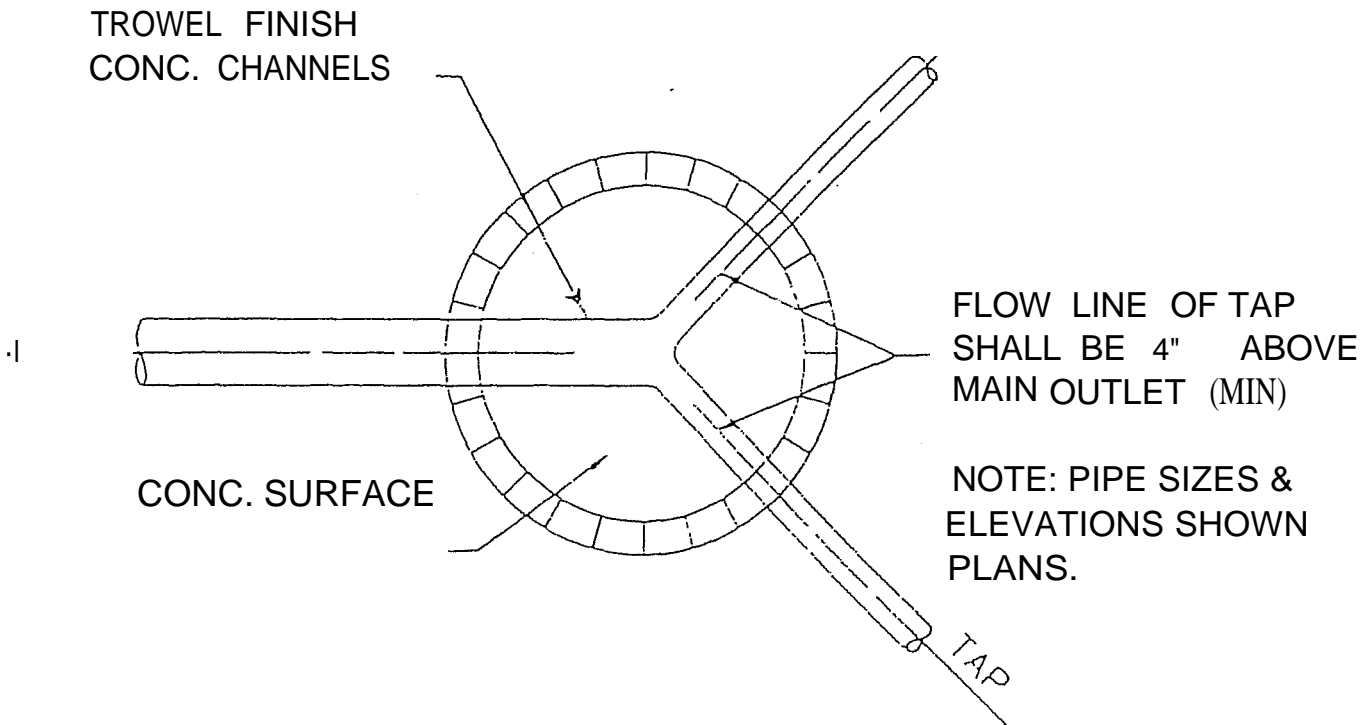

SERVICE TAP TO MANHOLE DETAIL

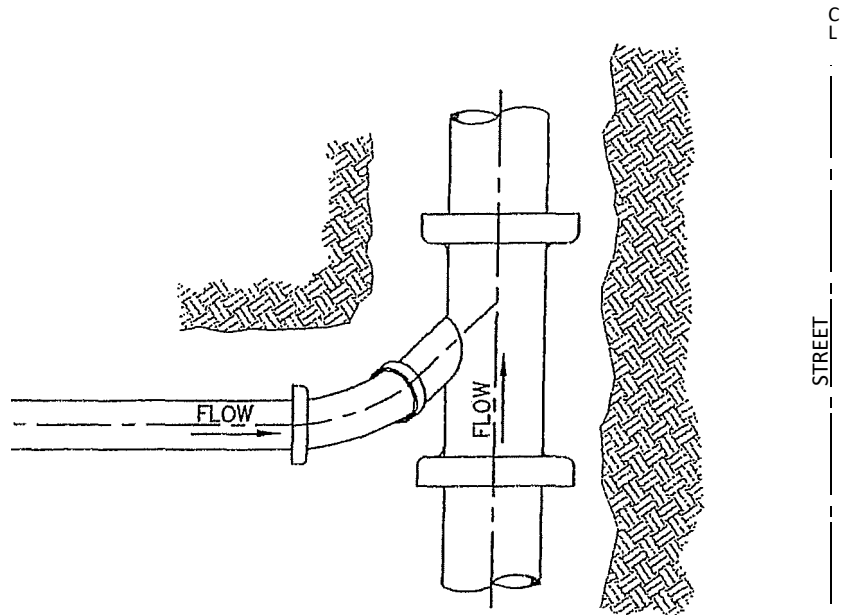

PLAN VIEW

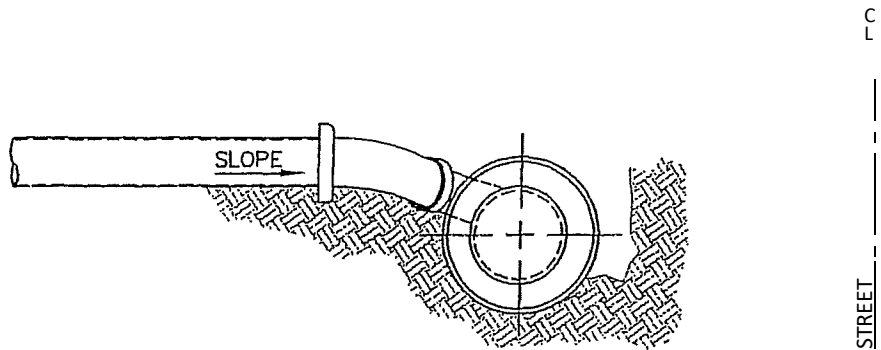

PROFILE

SEWER LATERAL DETAIL "A"
 FOUNTAIN HILLS SANITARY DISTRICT

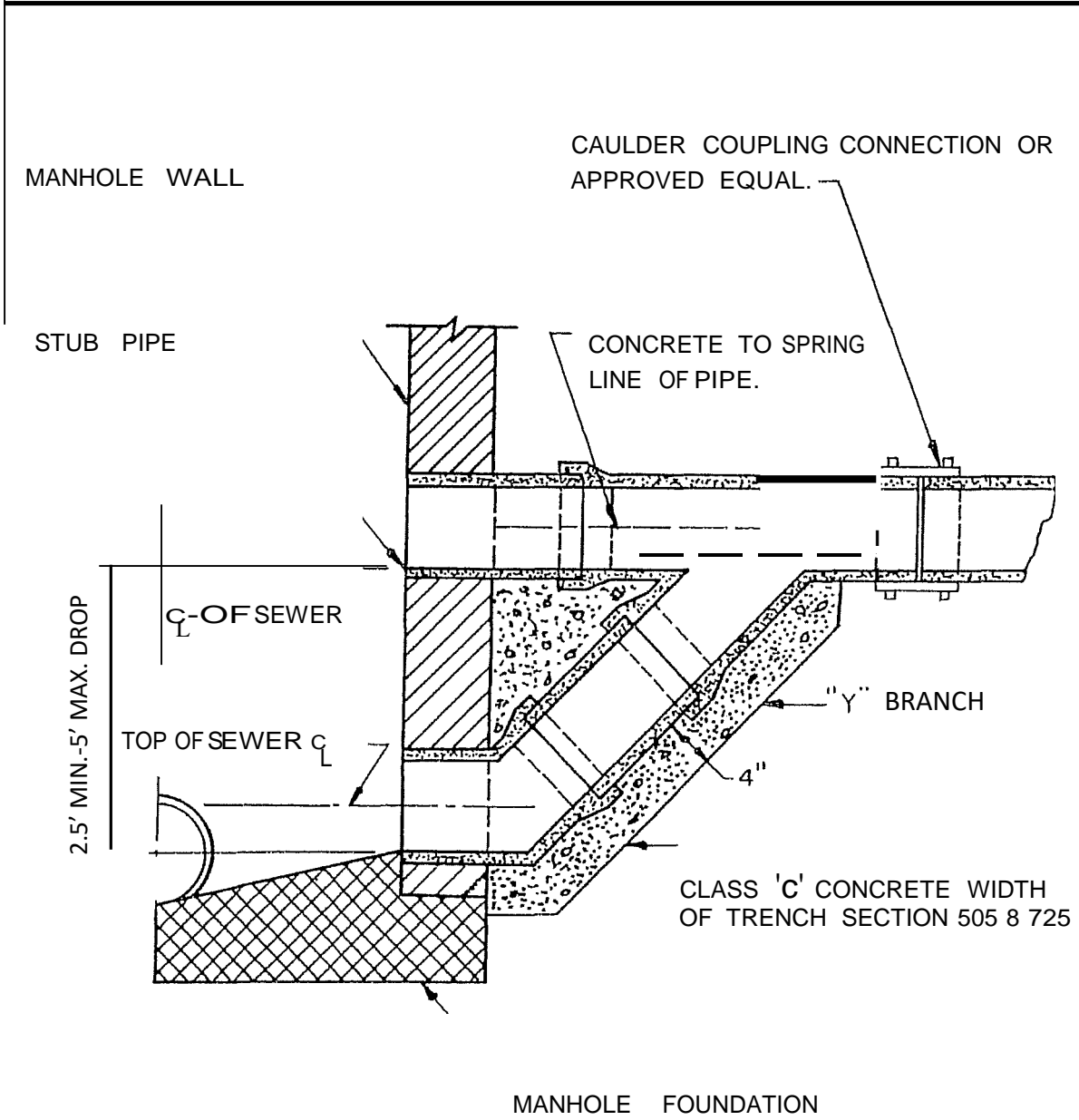

TYPE A
2.5' TO 5' DROP

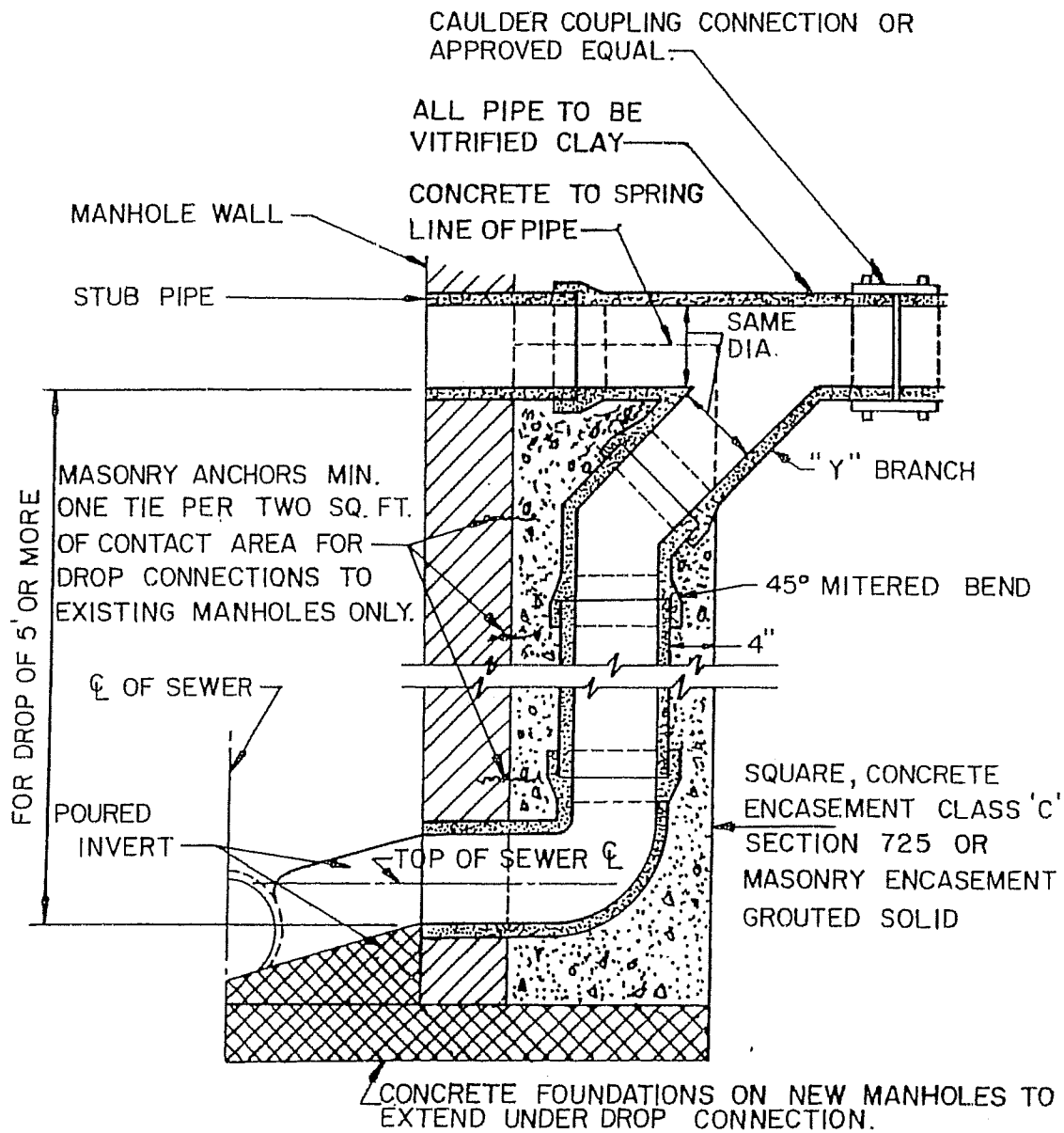

TYPE B

5' OR MORE